

Introduction

Colman's Model TJH and Model TJM floor grilles have been specifically designed to suit current industry requirements. With more and more buildings employing raised access floors in all types of applications from offices, computer rooms, telephone exchanges to universities and scientific establishments. Model TJH and Model TJM are principally designed to replace a 600mm square tile in raised access floor systems and are suitable for medium duty applications such as offices and heavy / extra heavy duty applications such as computer rooms.

Model TJH and Model TJM are aesthetically pleasing air distribution devices providing cool air exactly where required, eliminating high temperatures and reducing the risk of equipment failure.

Model TJH and Model TJM are suitable for both supply and return air and can be fitted with an optional opposed blade volume control damper (OBD) with adjustment through the grille face.

Specification

- Model TJH and Model TJM floor grilles are constructed from high grade aluminium extrusions to EN 755-9:2001.
- The thick aluminium profile extrusion for Model TJH and Model TJM framework is mitred and specially welded to form a robust and rigid frame.
- The Model TJH core comprises of 6mm aluminium bars set straight on a 12.5mm pitch, with the blades fully supported at the sides and across the grille centre for maximum strength.
- The Model TJH was independently tested to current floor grille specifications and complies to all loading and safety factor requirements.
- Weight: 17kg.

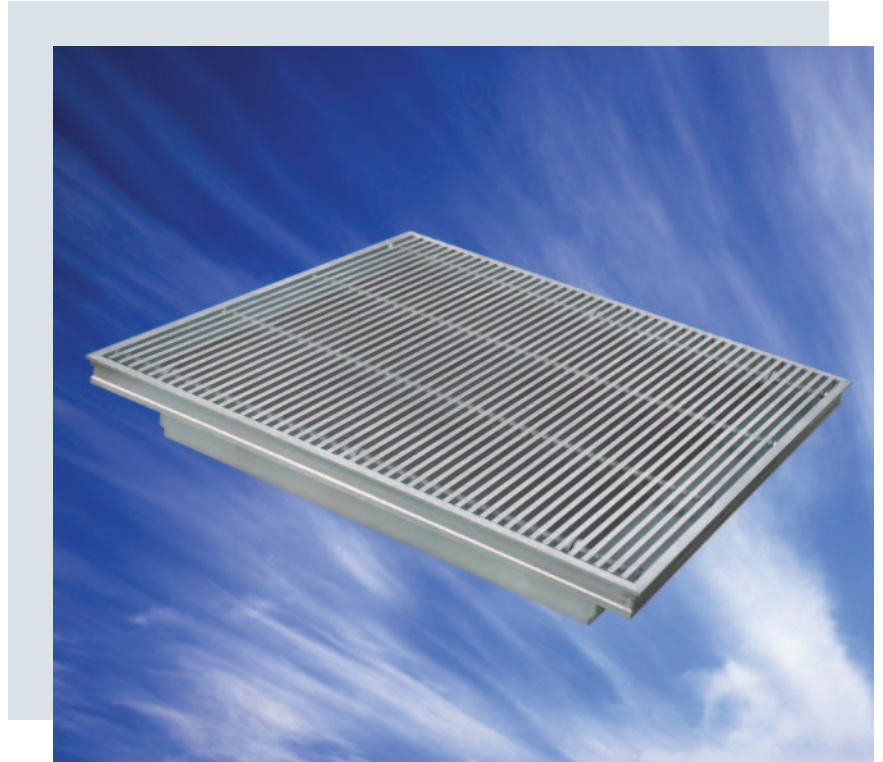

Testing

The Model TJH — Heavy / Extra Heavy duty floor grille complies with the requirements of the relevant sections of *PSA MOB PF2 PS/SPU* specification for Raised Access Floors March 1992 and IBM Management Design Guide for Raised Access Floors.

Finishes

Supplied in a standard natural finish, although alternative finishes in Nylon coatings, Polyester Powder in matt or gloss are also available. Additionally, there is a special option of a Shadow Line finish.

Please note that polyester powder finishes are only suitable in locations where predicted foot traffic is light.

Dimensions

Model TJH and Model TJM are supplied as a standard 599 × 599mm overall size to suit floor panel modules used by most flooring manufactures.

Special sizes are also available on request.

Installation

Model TJH and Model TJM are lay in floor grilles for raised access flooring systems and can be resited to suite changes in room layout without affecting the floor construction.

Corner sections are designed to accommodate most floor pedestal systems and tile thicknesses from 30mm to 90mm, including the final finish covering.

Model Types

Model TJH — Heavy / Extra Heavy duty floor grille.

Model TJM — Medium duty floor grille.

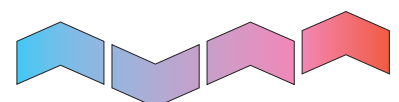

TECHNICAL SPECIFICATION & ORDERING INFORMATION

Performance Guide and Application

Volume (l/s)	Total Pressure (Pa)	Free Area Velocity (m/s)	Duct Velocity (m/s)	Noise Level (NR)
200	6	1.75	0.99	26
300	12	2.55	1.44	27
400	19	3.33	1.88	31
500	25	4.22	2.33	42
600	32	5.00	2.77	46

Structural Class (Model)	Typical Application
Medium (Model TJM)	General office accommodation where it is expected that heavy equipment will be used. Load: 3.0kN over 25mm x 25mm area. Safety factor Load of 9kN.
Heavy / Extra Heavy (Model TJH)	Computer rooms with heavy equipment and other special applications. Load: 4.5kN over 25mm x 25mm area. Safety factor Load of 13.5kN.

Based on 599 x 599mm overall grille size.

Notes: All figures shown include an Opposed Blade Damper (OBD) set fully open. When no damper is required a reduction of both 2NR and 2Pa can be applied to the noise and pressure figures stated.

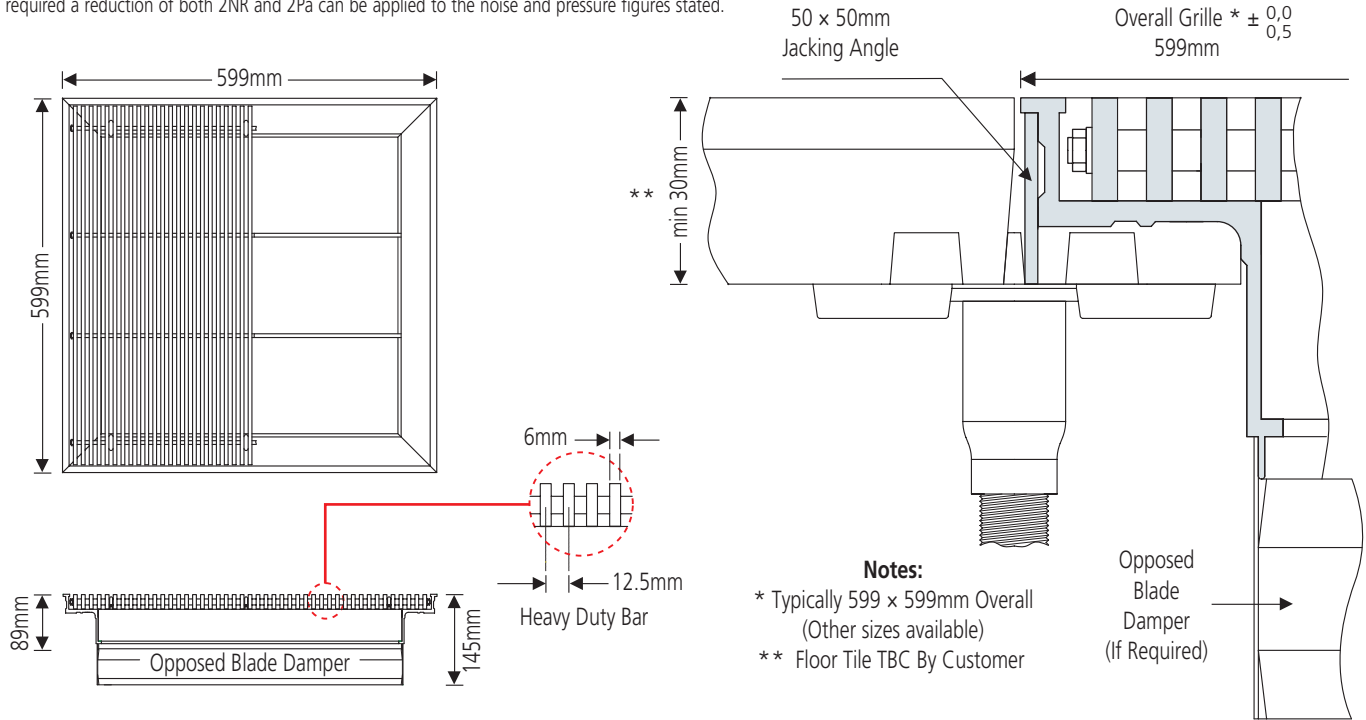

Options and Order Codes

1. MODEL	2. FRAME	3. APPLICATION	4. ACCESSORIES	5. ARRANGEMENT	6. FIXING	7. FINISH
T	J	H Heavy / Extra Heavy M Medium 1 Special	0 None V Volume control damper X Volume control damper painted matt black 1 Special	0 None	0 None	0 Natural P Powder coated N Nylon S Shadow Line 1 Special

T J H 0 0 0 0

TJH0000

Heavy / Extra Heavy duty floor grille. Finish: Natural.

Notes: Standard Nominal Grille Size — 600 x 600mm. Please specify tile depth when ordering (minimum 30mm). Items shown in red print above and in the code example are the standard options for this product.



marketing@dafnia.com
www.dafnia.com

UAE ABU DHABI DUBAI JAFZA OMAN MUSCAT QATAR DOHA
 +971 2 5557351 +971 4 3352995 +971 4 8831401 +968 24 750205 +974 44150543