

Empowered by Innovation

NEC

Introduction to the SL1000

SL1000 Newly Designed KSU



375(W) x 290(H) x 115(D) mm

- Common design for both main and expansion KSU
- Expansion capabilities within the Cabinet
- Shelf or wall mount capabilities

SL1000 Chassis

Main Chassis



Built in:

- Ethernet port
- 1 Channel VRS
- Door phones connect to hybrid extension port
- Configured as 4 analog trunks and 8 hybrid extensions
- Caller ID Send/Receive
- Conference

Expansion/Additional:

- 3 Expansion Cards
- VRS/Voicemail Card
- VoIP Card

Expansion Chassis

- Up to 3 Expansion Chassis can be installed
- Expansion chassis only required for additional TDM Trunk and Extension cards

SL1000 Platform - Capacity



Main chassis – includes:

- 4 Analog Trunks
- 8 Hybrid Extensions
- 3 Expansion slots

Main chassis – Maximum:

- 16 Analog or 12 BRI Trunks
- 32 Hybrid Extensions
- 16 IP Terminals + 16 IP Trunks



Expansion chassis – includes:

- 4 Analog Trunks
- 8 Hybrid Extensions
- 3 Expansion slots

Expansion chassis – Maximum:

- 16 Analog or 12 BRI Trunks
- 24 Hybrid Extensions



Maximum Capacity: Main Chassis +3 Expansion Chassis

- 48 Analog Trunks
- 36 BRI Trunks
- 16 IP Trunks
- 128 Hybrid Extensions
- 16 IP Terminals

SL1000 Platform – System Diagram

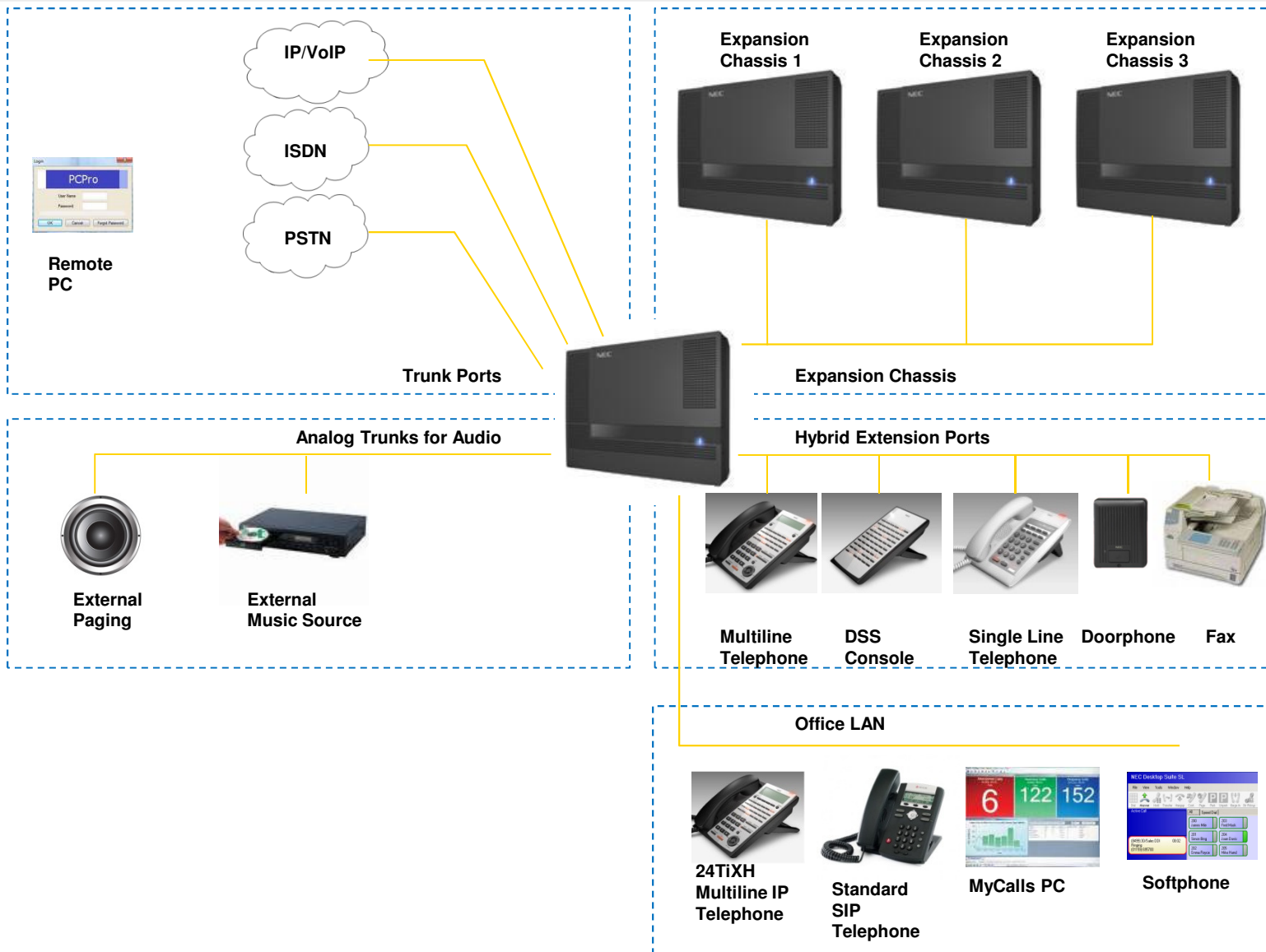

Hardware

Hardware

SL1000 Hardware description

Main
KSU 1632M



4 Analogue Trunks
8 Hybrid Extensions
3 Expansion slots

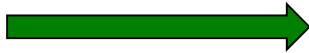

32 ports

SL1000 Hardware description

Main
KSU 1632M



4 Analogue Trunks
8 Hybrid Extensions
3 Expansion slots



32 ports

Expansion 1
KSU 1632ME



4 Analogue Trunks
8 Hybrid Extensions
3 Expansion slots



64 ports

SL1000 Hardware description

Main
KSU 1632M



4 Analogue Trunks
8 Hybrid Extensions
3 Expansion slots



32 ports

Expansion 1
KSU 1632ME



4 Analogue Trunks
8 Hybrid Extensions
3 Expansion slots



64 ports

Expansion 2
KSU 1632ME



4 Analogue Trunks
8 Hybrid Extensions
3 Expansion slots



96 ports

SL1000 Hardware description

Main
KSU 1632M



4 Analogue Trunks
8 Hybrid Extensions
3 Expansion slots



32 ports

Expansion 1
KSU 1632ME



4 Analogue Trunks
8 Hybrid Extensions
3 Expansion slots



64 ports

Expansion 2
KSU 1632ME



4 Analogue Trunks
8 Hybrid Extensions
3 Expansion slots



96 ports

Expansion 3
KSU 1632ME



0 Analogue Trunks
8 Hybrid Extensions
3 Expansion slots



128 ports

IP Extensions

16 ports

SL1000 Platform - Capacity

Number of chassis		Main chassis	Expansion chassis 1	Expansion chassis 2	Expansion chassis 3	Remarks
Total Ports		66	132	198	230	
Trunk Port	Max	32	48	64	64	
	Analog	16	32	48	48	
	ISDN BRI	12	24	36	36	
	IP Trunk (SIP/H.323)		16			VOIPDB & MEMDB is required
	External Paging	1	2	3	3	Use Analog Trunk ports
	External MOH	1	1	1	1	Use Analog Trunk port
	BGM	1	1	1	1	Use Analog Trunk port
Extension Ports	Max	32	64	96	128	
	Multi-Line Telephone	24	48	72	96	
	Single Line Telephone	32	64	96	128	
	IP Terminal (SIP-MLT/Std.)		16			VOIPDB & MEMDB is required
	DSS Console	3	6	9	12	Connect to Hybrid Extension ports
	Door phone	2	4	6	6	Connect to Hybrid Extension ports
Virtual Extension Port			50			
Power Failure Circuit		4	8	12	12	1 circuit per 408M/408E
Door Relay		2	4	6	6	Located on 408M of each chassis
Ethernet Port			1			Located on CPU
Built-In Answering Machine Channel			1			Built in to CPU
VRS Channel			4 / 16			CPU Max / CPU+MEMDB Max
Voicemail Channel			8 / 16			
Analog Modem			1			Mounted on PZ-VM21





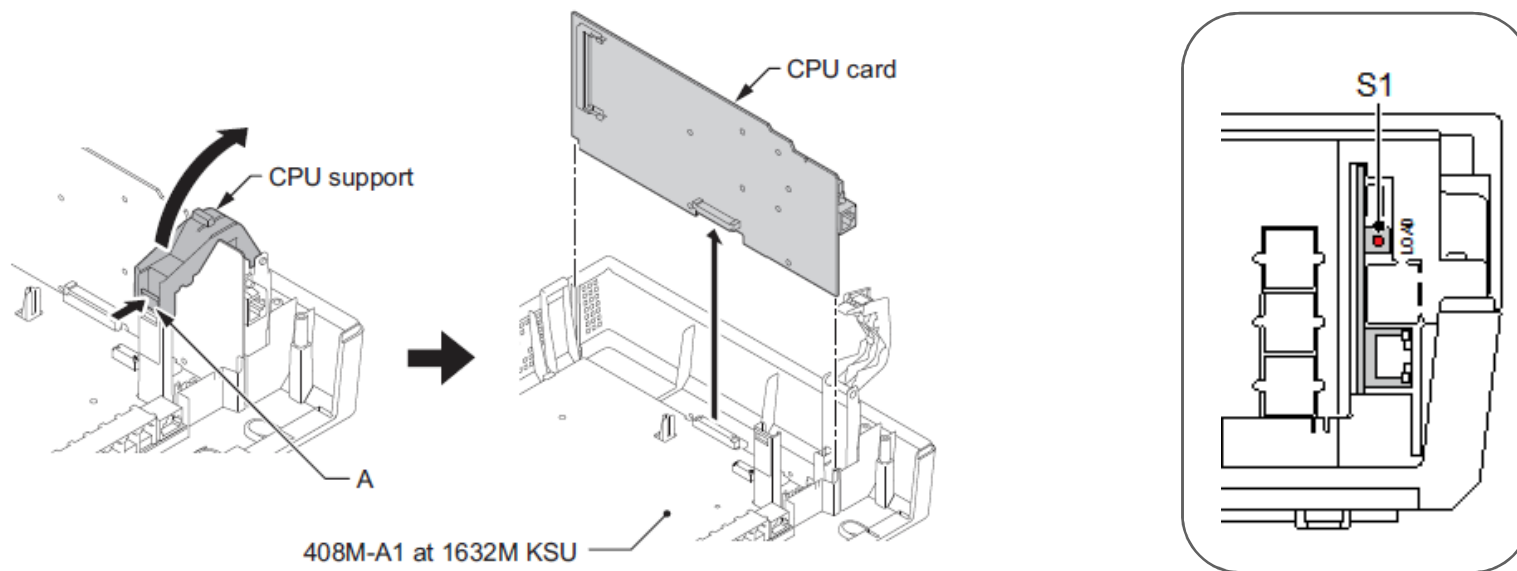

CPU Card

CPU card

- Add on daughter cards
 - MEMDB, VM21, VoIPDB
- Red, load button (S1) – Default and local upgrades
 - Push and hold for 10 seconds to default, or when D5 starts to flash



SL1000 Hardware description

MEMDB	-Additional Memory Required for IP and expansion (1632ME)	
VoIPDB	- VoIP (16) daughter card	
EXIFB	- Expansion module card	
VM21	- Daughter card for InMail Analogue Modem Required for Software upgrades	
IPWW CFVRS	- 4 port VRS only CF (Compact Flash card)	
IP4WW CFVMS	- 2 port InMail CF and 4 Port VRS (Compact Flash card)	

Inside the Chassis

Main Chassis comes configured as 4 Analog Trunks and 8 Hybrid Extensions

Trunk and extension expansion boards

CPU + InMail and VOIP daughterboards

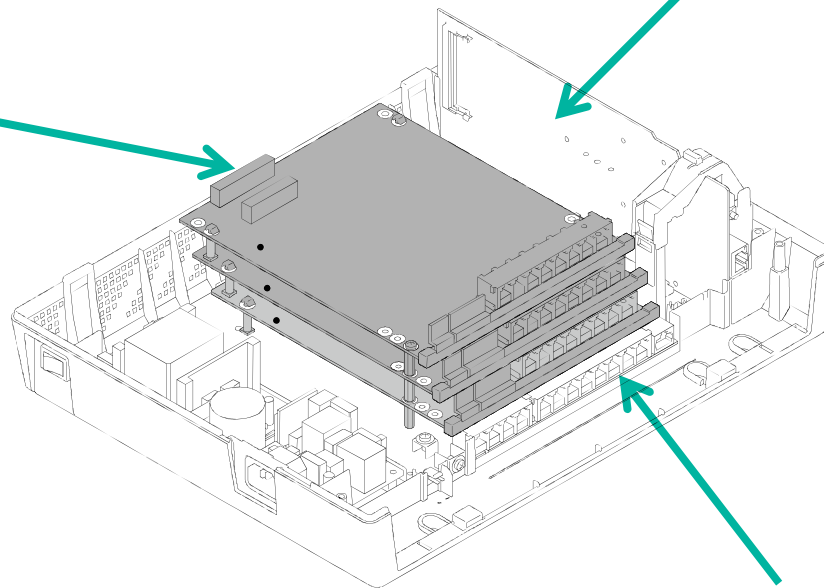

RJ11 connections

SL1000 Hardware description

- 3 base cards
- 408E - Expansion card*** (4x Analogue trunk + 8x Hybrid extensions)
- 008E - Expansion card*** (8x Hybrid extensions + slot to install 2BRI)
- 000E - Expansion card (Slot to install 2BRI)

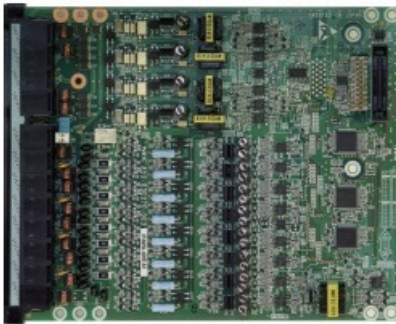

408E

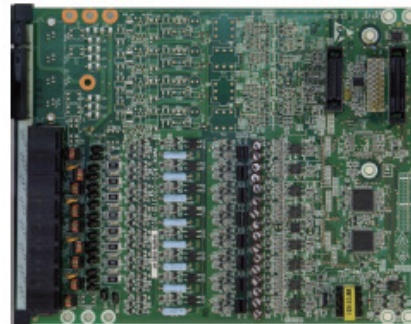

008E

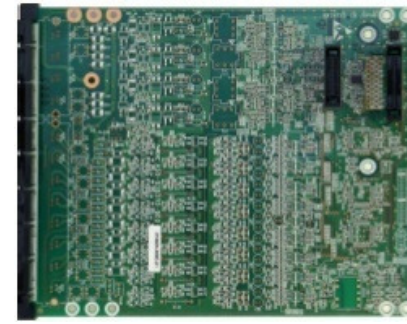

000E

*** Note – when installed in 4th Slot - **No Keyphones** are supported
when installed in 4th Chassis – **No Trunks** are supported

Expansion 408E

408E

- 4 Analogue trunks
- 8 Hybrid extension ports

Extension Port 8 –

- One of following devices

- Hybrid (KT)
- DSS (KT)

- SLT with power fail (PF)



RJ11 connections for extensions and trunks

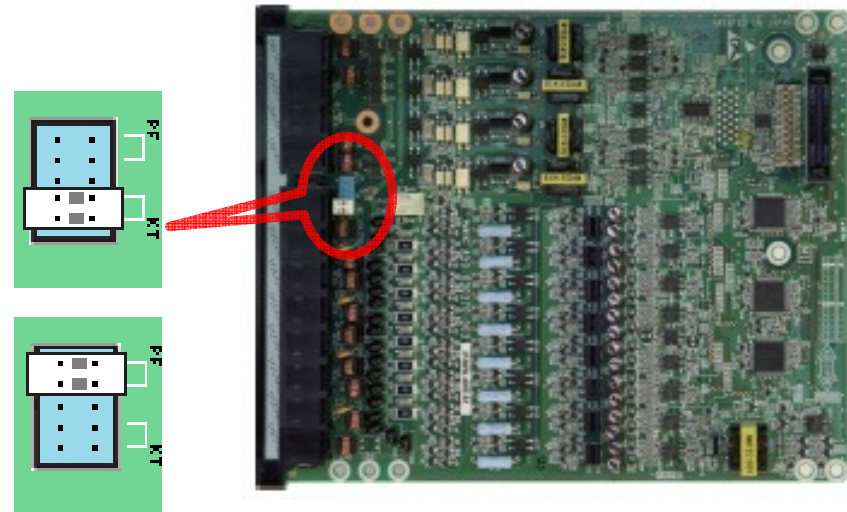

408E

Expansion 008E

008E

- 0 Analogue trunks
- 8 Hybrid extension ports

Extension Port 8 – No Power fail

- Hybrid or
- DSS

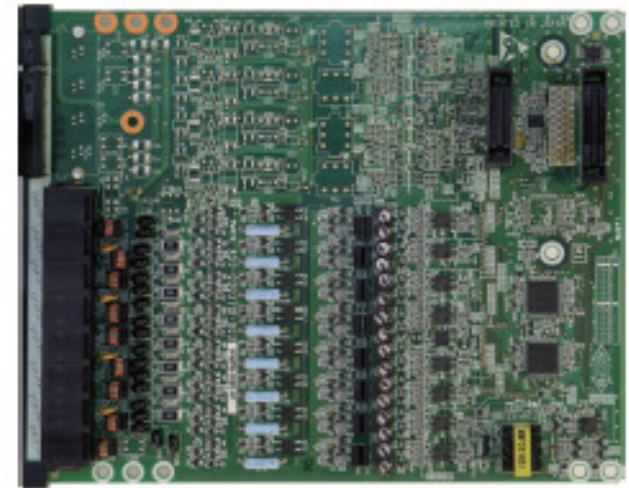

008E



RJ11 connections for extensions

Expansion 008E + 2BRI

008E + 2BRI

- 0 Analogue trunks
- 8 Hybrid extension ports
- 2 BRI (4 Channels)

Extension Port 8 – No Power fail

- Hybrid or
- DSS

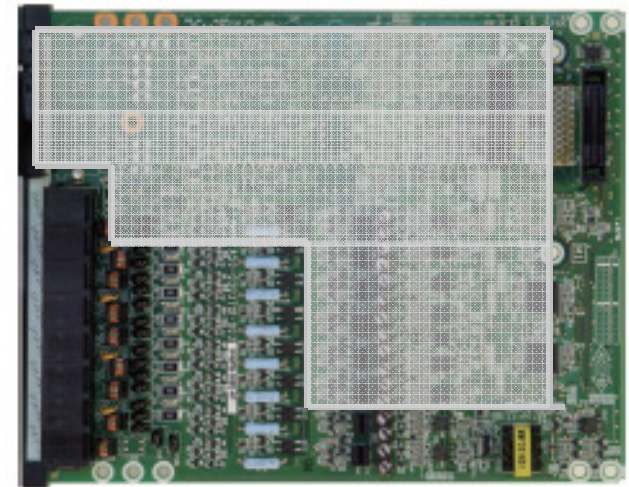

008E + 2BRI

Daughterboard 2 BRI



RJ11 connections for extensions,
RJ45 for BRI

Expansion Chassis Connection Card: EXIFB & EXIFE

Main to Expansion Chassis connection requires an EXIFB Card installed into the Main chassis.

Use a CAT5 cable to connect the EXIFB card to the EXIFE card in each Expansion chassis.

- Up to 3 Expansion Chassis(s) can be installed
- EXIFE card and 0.5m CAT5 cable are supplied with the Expansion chassis

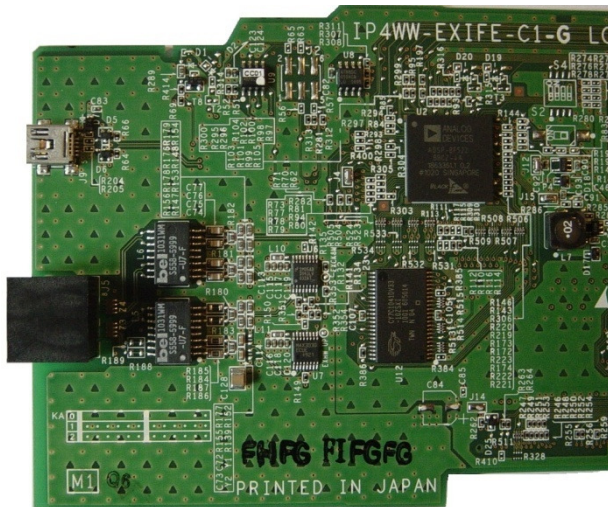

EXIFE in each Expansion chassis

CAT5 cable to
Expansion chassis 3

CAT5 cable to
Expansion chassis 2

CAT5 cable to
Expansion chassis 1

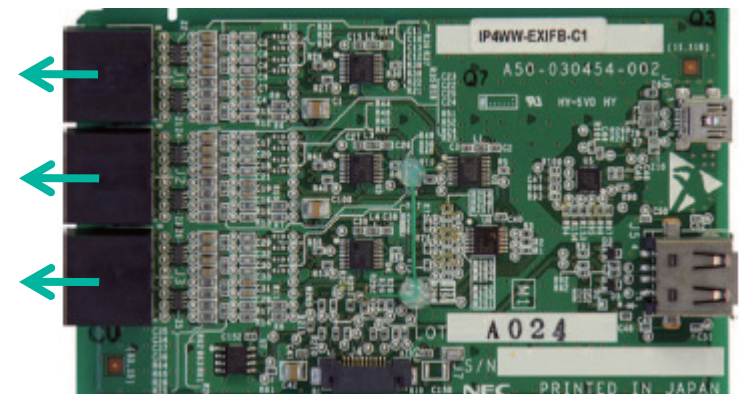

EXIFB in the Main chassis

MEMDB Memory Expansion Card

The MEMDB card is installed in the Main Chassis.

- 1 MEMDB card can be installed

The MEMDB card is only required if:

- An Expansion Chassis is installed
- The VoIP card is installed
- Remote software upgrade is required
- E-Mail Notification is required (InMail)
- VRS Channels greater than 4 are required
- InMail Channels greater than 8 are required

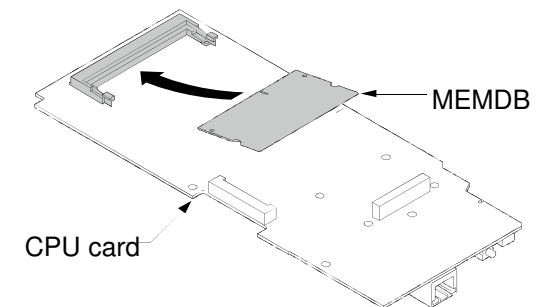
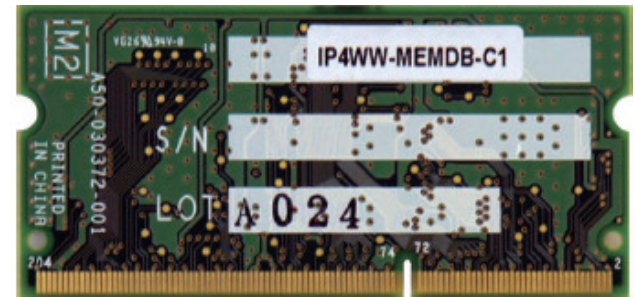

VoIP Card

The VoIP card is installed in the Main Chassis *

- 1 VoIP card can be installed

The VoIP card provides:

- 16 IP Resources for IP trunks or IP extensions/Softphone
- 4 SIP Trunk licenses are included

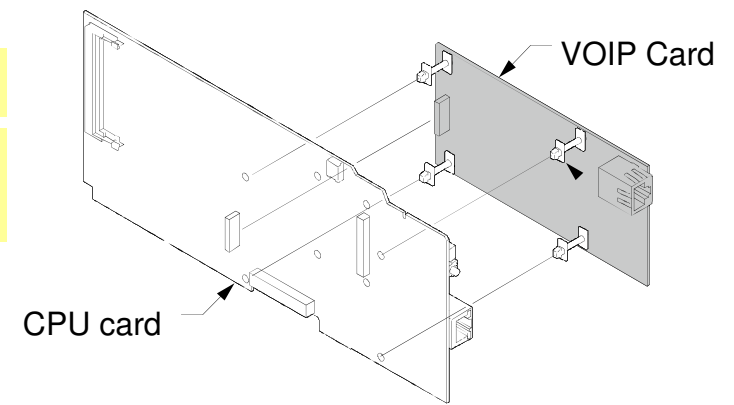
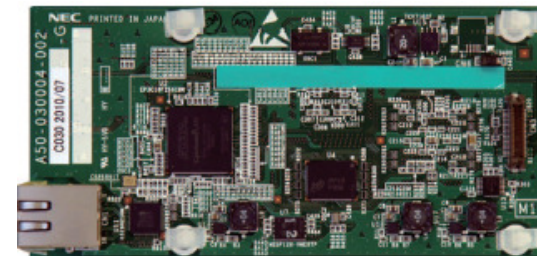
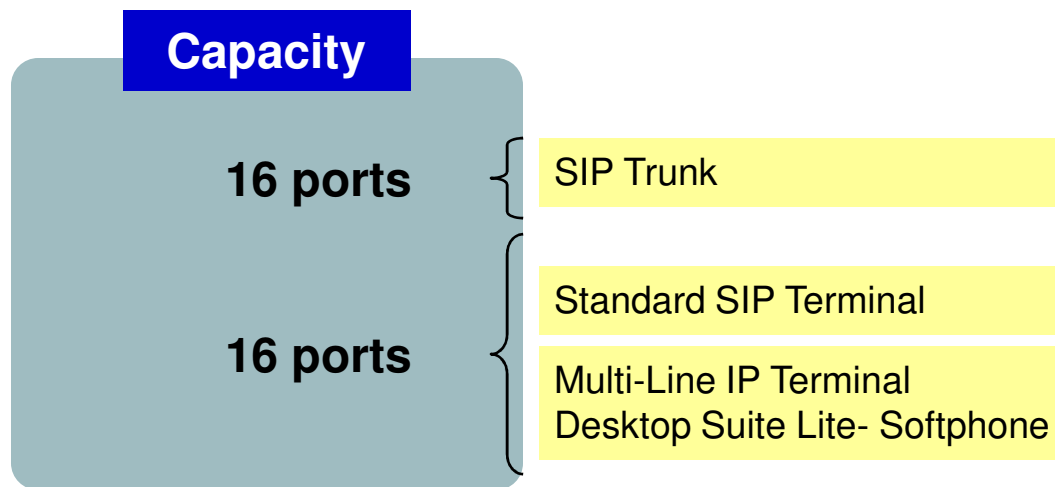

* The MEMDB card must also be installed.

DHCP Server related commands

- 10-13-01 DHCP server enable
- 10-13-02 IP lease time
- 10-14-01 range of IP address for leasing
- 10-15-01 Lease Fixed IP address to a client

- 10-63-01 DHCP Client configuration

Note : to assign IP address manually press (hold =>Transfer=> * #) buttons.

External Battery Backup

Main & Expansion chassis can have an external battery box connected

- One battery box required per chassis
- 2 x 12v 7Ah batteries per box
- Approximately 1 hour backup duration



Battery Box

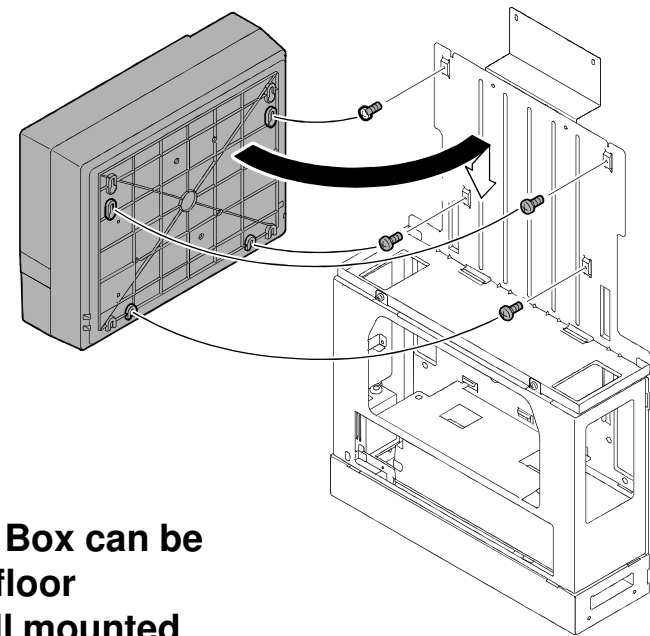

**Battery Box can be
floor
Or wall mounted**

VRS / Voicemail Card

The PZ-VM card is installed onto the CPU card in the Main Chassis

- 1 PZ-VM card can be installed

The PZ-VM card provides:

- A Compact Flash Card slot
- Analog modem for remote access

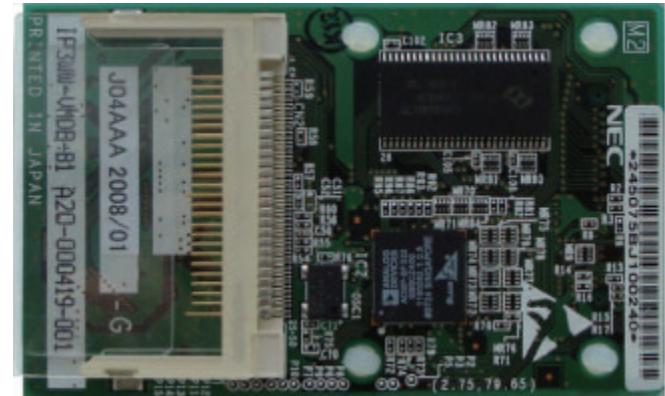

There are 2 Compact Flash cards available:

- VRS
- VRS + InMail

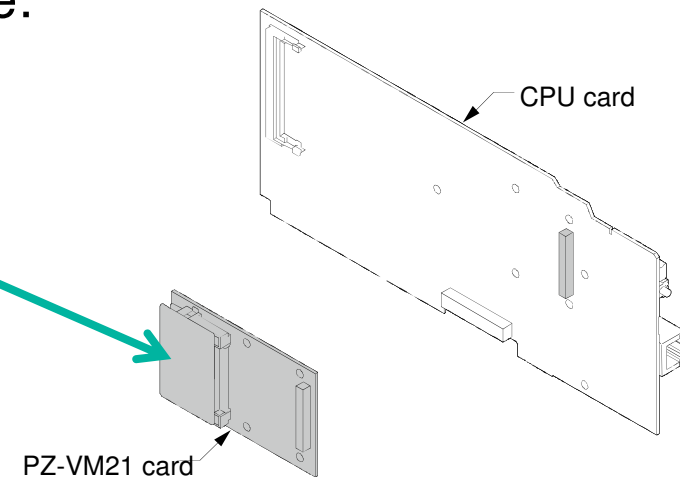

VRS / Voicemail Compact Flash Cards

The Compact Flash card is installed onto the PZ-VM Card

- Only 1 Compact Flash card can be installed

The VRS Compact Flash card provides:

- VRS: 4 channels, 100 messages
- Multi Language prompts (24 languages)
- Upload languages via User Administrator (WebPro)
- Queue Announcements

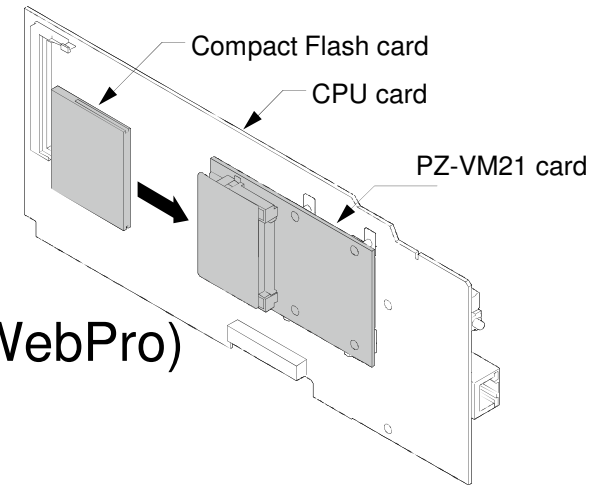

The VRS + InMail Compact Flash card provides:

- The same features as the VRS card plus:
- 2 Channels, 15 hour storage capacity
- 128 Extension Mailboxes, 16 Call Routing Mailboxes
- Multi Language prompts (24 languages)

VRS Related Commands

- 25-02-01 Talkie =1 Data = 1 (message number)
- 22-02-01 Type = 1
- 25-06-01 VRS receive digit setup
- 25-07-02 VRS/DISA no answer timer
- 25-04-01 VRS/DISA no answer destination group
- 14-02-09 Busy tone detection

InMail related commands

- 11-07-01 enter a pilot number in group 32 (e.g 600)
- 47-01-17 assign InMail starting port (dummy extension port)
- 16-02-01 assign all dummy extension to group 32
- 15-03-03 assign all dummy extension to Type-1 (special)
- 15-03-01 assign all dummy extension as DP
- 45-01-01 voice mail department group No. 32
- 47-02-02 Mail Box setup

Assigning key

Check voice mail : Speaker 851+(select key)+77+ (VM pilot number) speaker

Voice mail forward key : Speaker 851+(select a key)+79 +(enter mail Box No)
speaker

Networking

The SL1000 does not support:

- KCCIS, NetLink or AspireNet

The SL1000 can be connected via SIP trunks

- Desk to Desk dialing
- Remote PSTN break out
- Company wide numbering plan

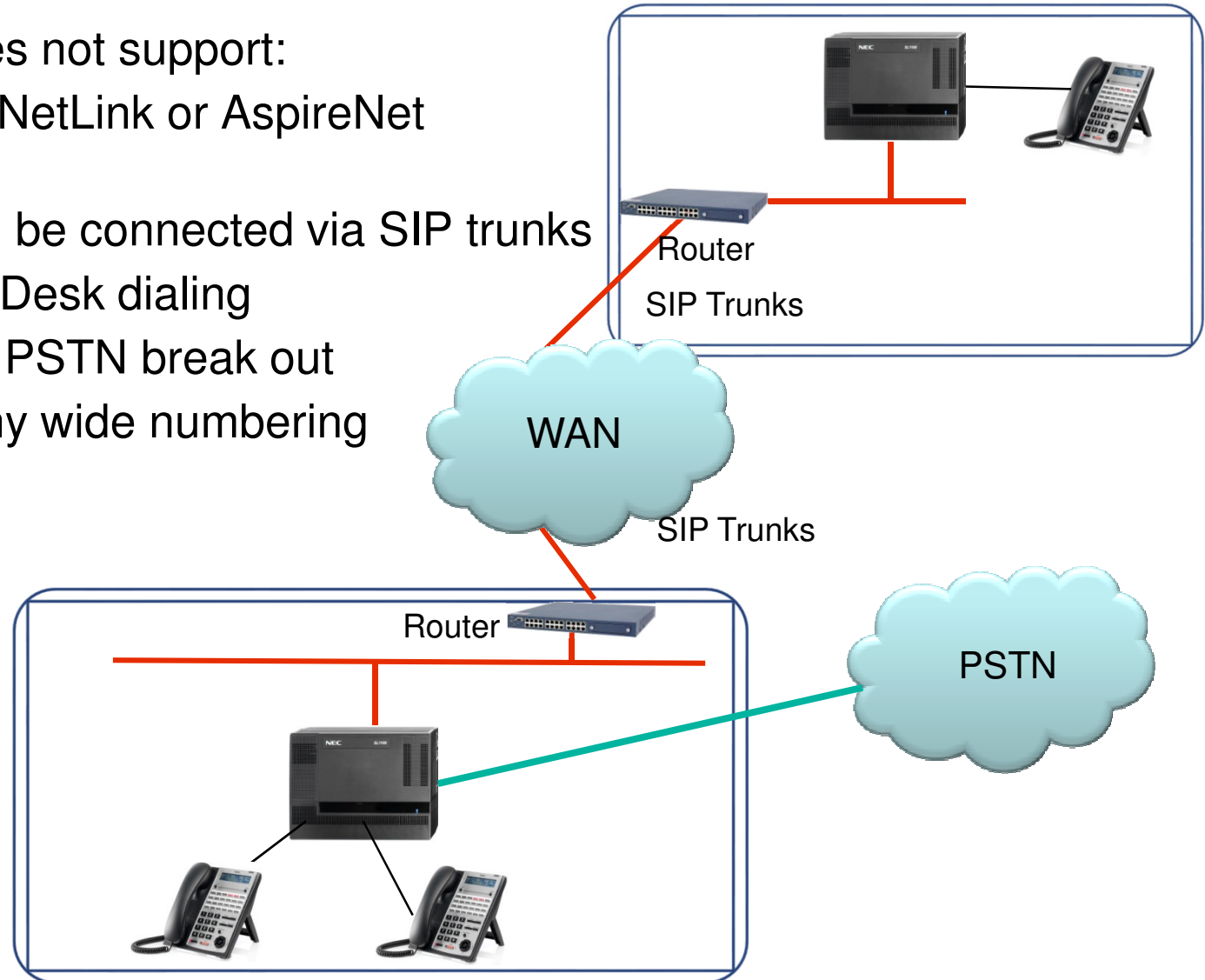

Terminals

Terminals

Terminals – 12 Key with Display

IP4WW-12TXH-A

Main Features

- 12 Line Keys
- 2 line display
- Half duplex Handsfree
- Cursor keys
- 2 Step adjustable legs
- Built in wall mount



Terminals – 24 Key with Display

IP4WW-24TXH-A

Main Features

- 24 Line Keys
- 2 line display
- Half duplex Handsfree
- Cursor keys
- 2 Step adjustable legs
- Built in wall mount



Terminals – 60 key DSS Console

IP4WW-60D-DSS-A

Main Features

- 60 Line Keys
- 2 Step adjustable legs
- Installed alongside 12 or 24 key terminal
- Maximum of 12 DSS
 - 3 per KSU



Terminals – DR700 IP 24 Key with Display

IP4WW-24TIXH-C

Main Features

- 24 Line Keys
- 3 line backlit display
- Full Duplex Handsfree
- Cursor keys
- Soft Keys
- Headset port
- Wall mounting kit (optional)

- 2x Ethernet ports LAN / PC
- 10/100 LAN connections
- POE support
 - IEEE 802.3af
- Or External power supply
- **Max 16 on system**



Requires MEMDB + VoIPDB Card

SL1000 Key Indication & LED

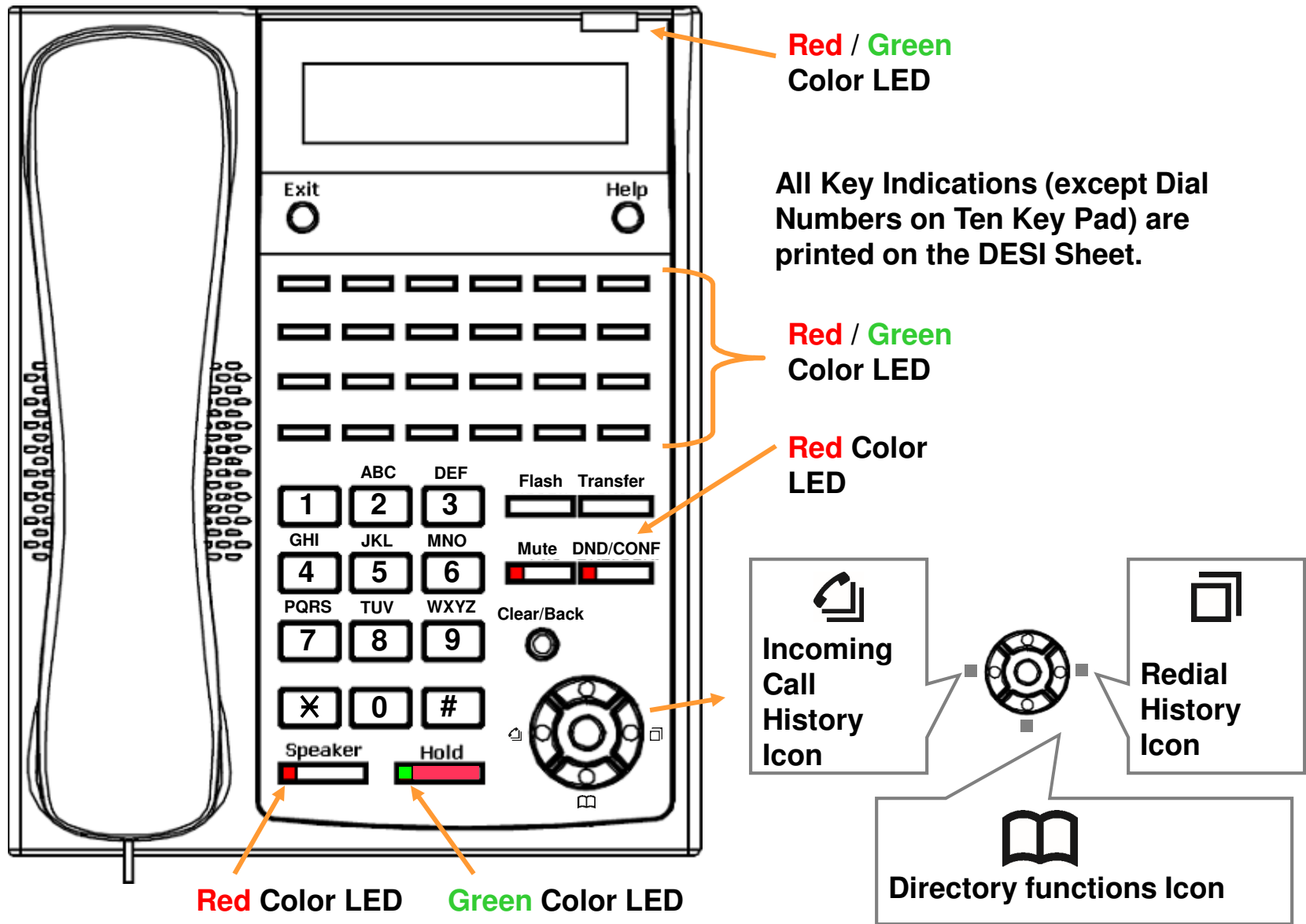

Motherboard Ports

Motherboard Ports

Motherboard ports

KSU 1632M / ME Motherboard

4 Hybrid Analogue trunks



 Analogue Trunk

 External paging

 MOH - Music on hold source

 BGM - Background Music source

Trunk Port Position



CO4 CO3 CO2 CO1



Or Or Or



Motherboard ports

KSU 1632M / ME Motherboard

8 Hybrid extensions

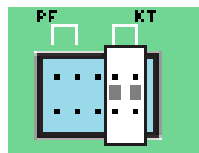

Extension Port Position

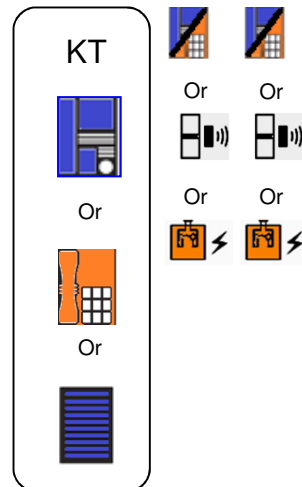

 Hybrid port

 Keypoint

 SLT

 Doorphone

 Sensor

 DSS Console

Motherboard ports

KSU 1632M / ME Motherboard

 2 Relays

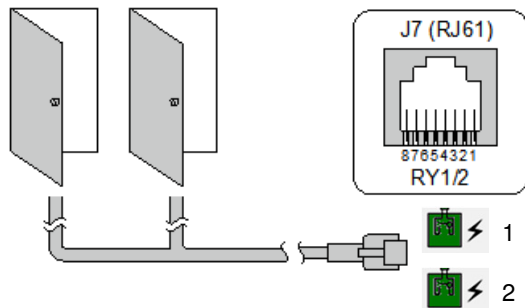

Lock release

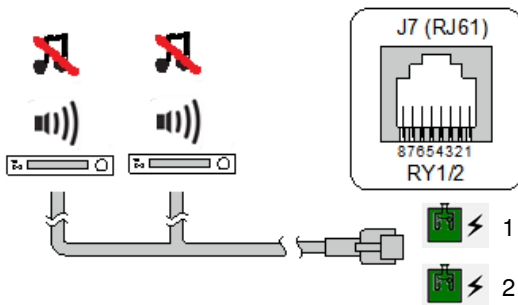

Or External paging Mute

MOH & BGM related commands

■ 10-03-01 Slot 1

Port 3 = MOH (logical port = 0 , Port Type = 1)

Port 4 = BGM (logical port = 0 , Port Type = 1)

■ 10-04-01 External

■ 14-08-01 External/Internal or BGM source

Installation

Installation

Opening main cover and Earthing point

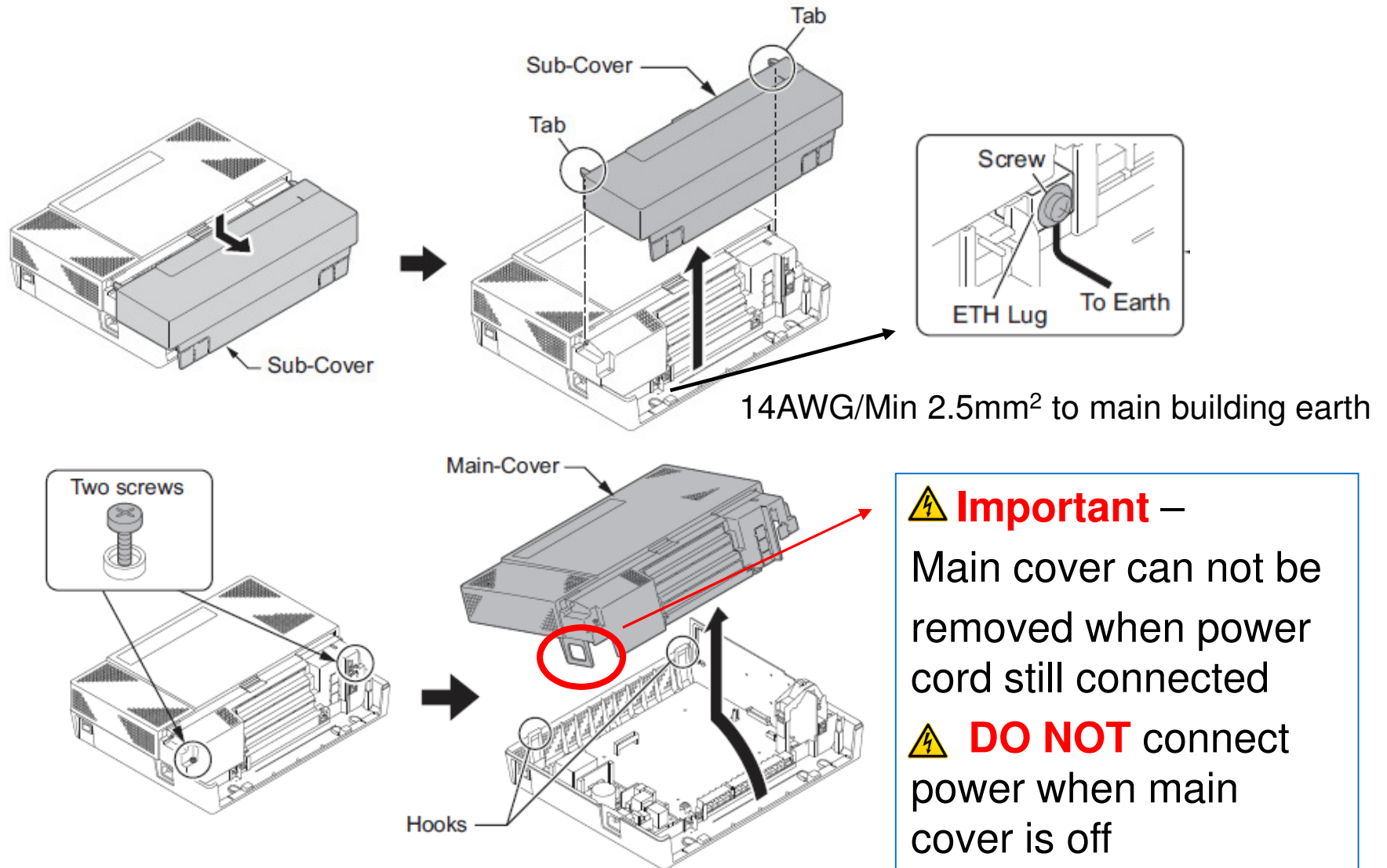

Re-fitting cover

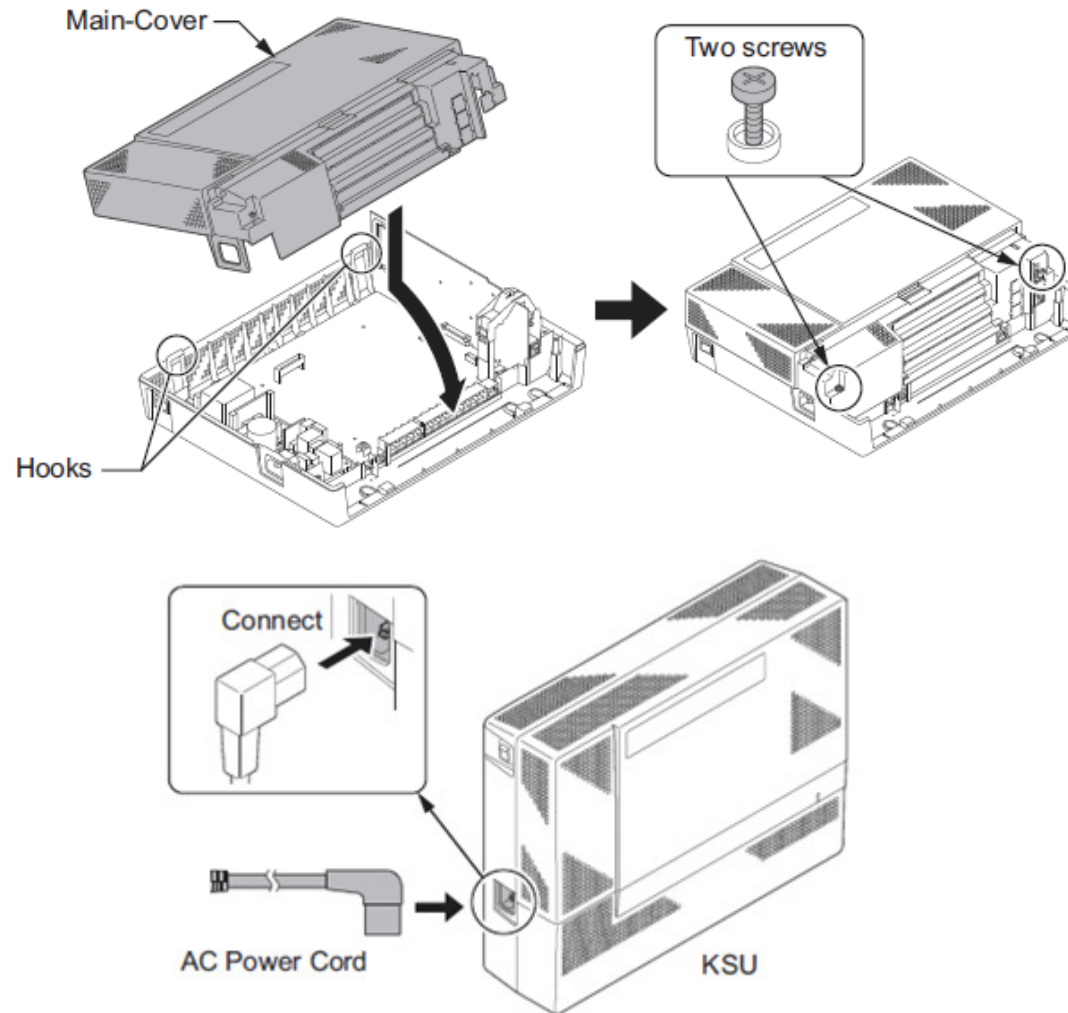



Wiring

Wiring

Audio Ports wiring

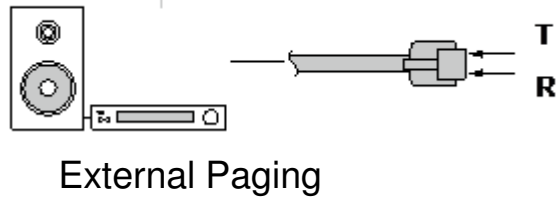
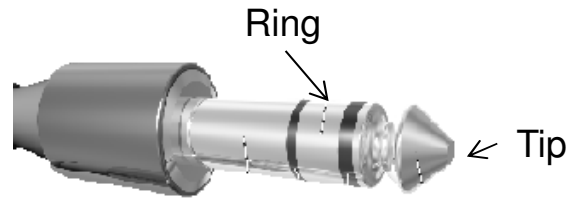
Audio ports



CO2	External Paging 
Pin 3	Ring
Pin 4	Tip

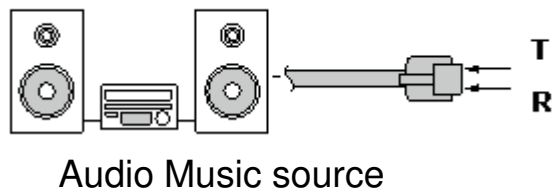

CO3	Music on Hold 
Pin 3	Ring
Pin 4	Tip

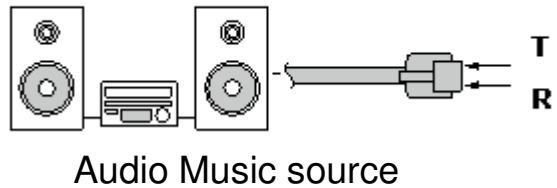

CO4	Background Music 
Pin 3	Ring
Pin 4	Tip

Installation - Sensor Wiring

RJ11 colour code

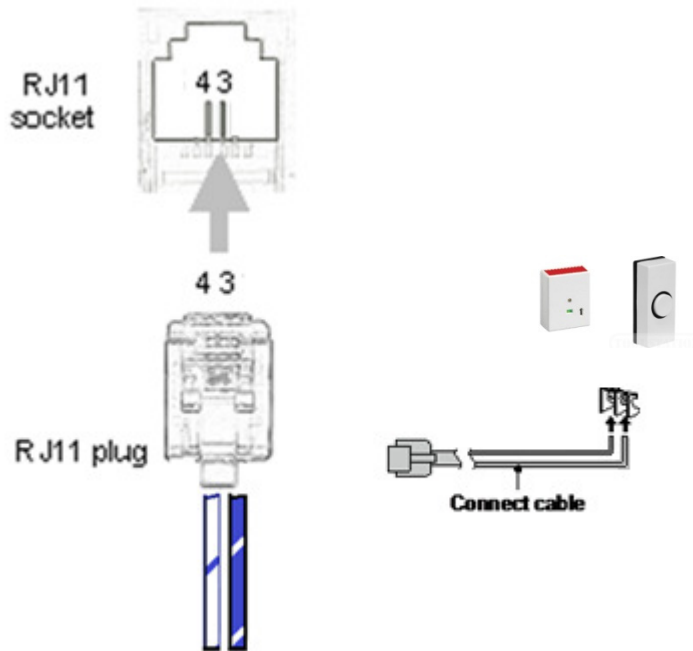

ST6/7	Sensor
Pin 3 Blue/white	B
Pin 4 White/blue	A

Relays

Multi purpose relay

2 Relays per KSU connection RJ61

Used for

- Lock release or
- External Paging mute

Provides dry contact (Form A)

- Max power DC 48V
- Max current DC 320mA

Normally open

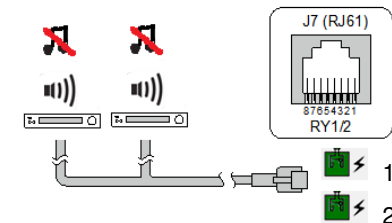
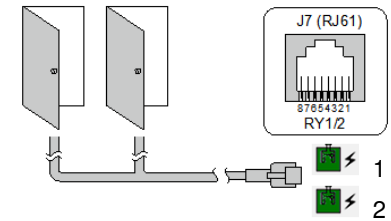

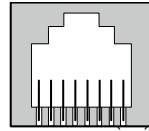
	Pin No.	Connection
 87654321	1	-
	2	-
	3	Relay 2
	4	Relay 1
	5	Relay 1
	6	Relay 2
	7	-
	8	-

Software upgrade

Software Upgrade

Latest version is

System information

System software version

- Enter Key + 821
 - Version
 - Hardware key

Main Ver: 1.20
HWK : 280000000111

- Right key to view MAC address

Main Ver: 1.20
0060-B9D8 - XXXX

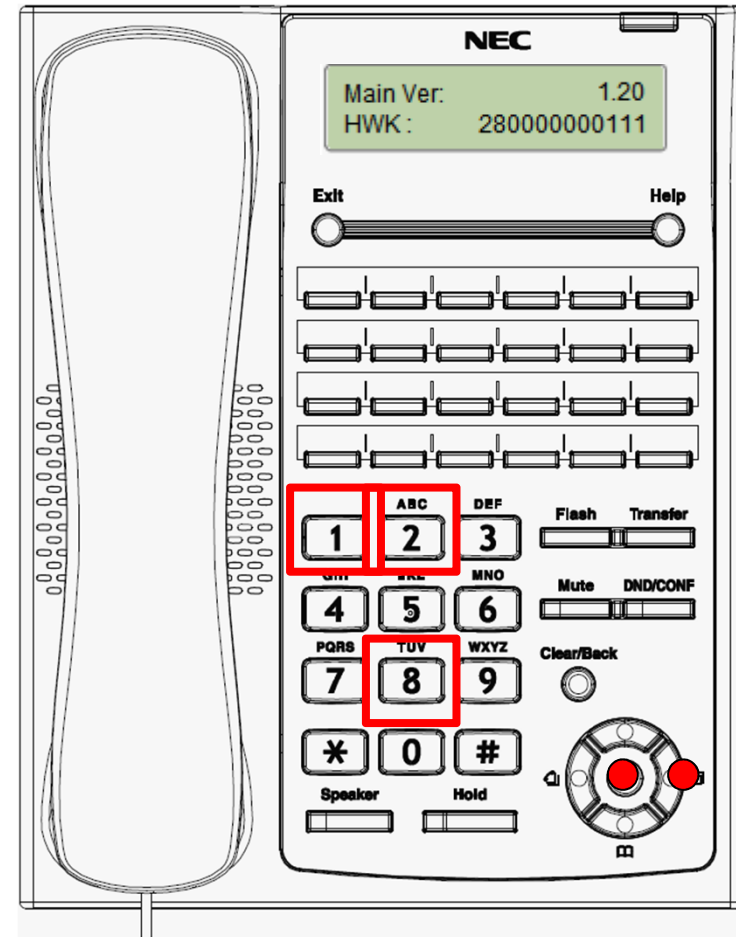

Front LED

Upgrade LED sequence

● Stage 1



● Stage 2



● Stage 3



● Stage 4

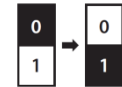

Normal boot up (30-40 seconds)

Loading data (3 -3 ½ minutes)

Upload complete (until re-boot)

Re-boot System



Software upgrade

Software upgrade

Require VM21 and CF1 with software on root directory

1. Ensure system is powered off and Insert CF
2. Power up with red button pressed
3. Hold for 10 seconds or when D5 begins to flash
4. Main LED - triple flash red as loading (also D4)
5. D4 and D3 flashing – upgrade completed
6. Power down, remove CF and reboot

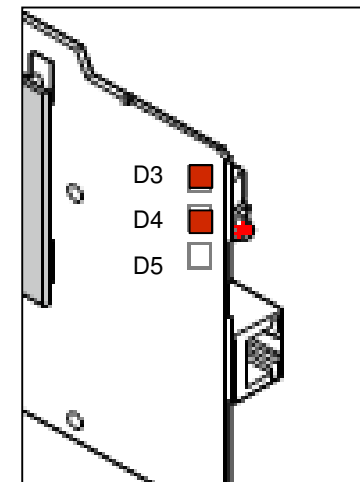
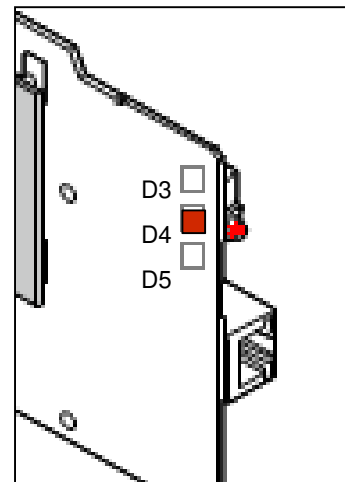
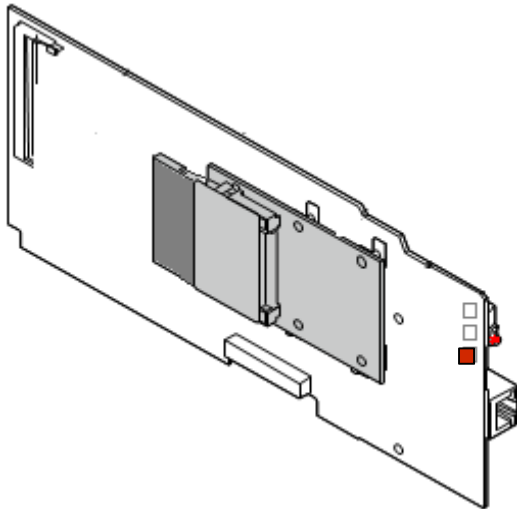

Licensing

Licensing

Licensing

SL1000 has built in License's

- some are activated by hardware

License / feature information	Number of Licenses	Hardware controlled	Notes
InMail Port license	2	IP4WW CFVMS + VM21	Each additional license adds 2 channels Max 8 channels w/o MEMDB Max 16 channels w MEMDB
Mobile extension	4	KSU 1632 M	Each additional license adds 1 mobile extension Max 32
SIP Trunk License	4	MEMDB + VoIPDB	Each additional license adds 1 SIP trunk Max 16 **Requires MEMBD + VoIPDB
DR700 24 Key IP Phone	No License required	DR700 24 key IP Phone + MEMBD + VoIPDB	No additional license required Max16 can be installed **Requires MEMBD + VoIPDB
Loopback ports	30 Extn/30 Trk	MEMDB	10-42-01 is not allowed unless MEMDB installed

SL1000 Licensing

Feature	License Name	Description	Type of license	System max
SIP Trunk	SL-IPSIPTRK 1 LIC	SIP Trunk	1 Port (4 licenses included in KSU 1632M)	16x SIP Trunks
SIP Extension	SL-IPSIPEXT 1 LIC	SIP Extension	1 Port - 3 rd Party SIP Extension	16 x 3 rd party SIP Extension
VoIP Encryption	SL-IP-ENCRYPTION LIC	Encryption license for DR700	System wide	1
VoIP NAPT	SL-IP-NAPT LIC	NATP License for DR700	System wide	1
InMail	SL-VM-CHANNEL-2 LIC	Additional InMail Port license (2ch)	Adds 2 extra channels (Hardware = 2 channels)	8 x Channels w/o MEMDB 16 x Channels w MEMDB
InMail Advanced	SL-VM- ADVANCE-LIC	InMail advanced feature license -E-Mail Notification -Cascading message notification - Find me / Follow me -Remote auto login to mailbox -InMail Hotel features	System wide	1 <u>Note</u> MEMDB Required for E-mail notification
Mobile Extension **	SL-SYS-MOBILE-1 LIC	Additional mobile extension	Adds 1 extra mobile extension (4 licenses included in KSU 1632M)	32
Hotel /Motel **	SL-SYS-HOTEL LIC	Hotel feature license	System wide	1

**Power reset required

Programming

Programming

Telephone programming

■ SL1000 out of box default

■ 11-01

- Trunk access = 0 (also 11-09)
- Operator access = 9 (also 20-17-01 = 200)
- Extension = 1xx,2xx,3xx,4xx,5xxx,6xx
- Services codes = 7xx, 8xx, *x, #x and #*xx

■ 15-02-34 Extension call register

■ 25-02-01 default message No. 1

Service codes

Service codes

Single digit service codes

Default single digit service codes

Description	Active code
Step Call	4
Off hook signalling	*
Voice/signal call switching	1
Camp-on	3
Message waiting	0
Voice over	6
Voicemail access	5

Middle East script replaces # for a 3

Shortened Service codes

Original code	Description	New code
891	Account Code	##
805	Trunk Specified Access	#0
843	Call Forward Busy	#1
813	Speed Dial Common/Station	#2
806	Flash on Trunk Lines	#3
814	Speed Dial Group	#4
816	LND	#5
831	Park Hold	#6
761	Speed Dial Station (One Touch)	#7
753	Unsupervised Conference	#8
872	Universal Answer	#9
867	Call Pickup for Own Group	*#
715	Call Pickup Direct Extension	**
841	Message Waiting Answer	*0
751	Paging Combined Paging	*1
861	Park Hold Answer	*6
717	Voice Mail Access	*8
720	Common Cancel Service Code	*9

Applications

Applications

Applications

Applications

- SL MyCalls
- SL MyCalls Call Manager
- SL Desktop Suite Lite
 - Softphone
 - Deskset
- LMS licenses required

MyCalls for the SL1000

SL MyCalls

- Reports on all extensions and all trunks/DDIs

Key Features

- Integrates with system data: Easy Configuration
- Call Costing: Telephone call cost associated with users
- Call Information: Incoming calls, Outgoing calls, Abandoned calls etc
- Directors Report : Summary report at end of the day
- Historical reports :
 - Define a report and layout
 - Run the report on demand

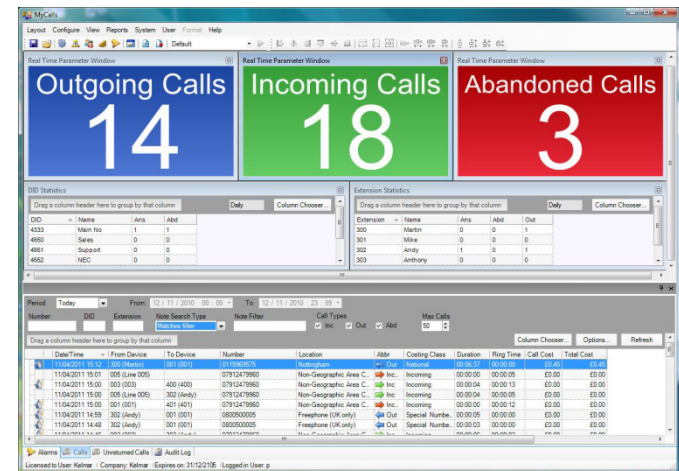

MyCalls - Licenses

SL MyCalls

- Free of charge for 1st year : After 1 year customer decides either:
 - Buy never expiring SL MyCalls license
 - Buy never expiring SL MyCalls Call Manager license

SL MyCalls Call Manager

- Additional Users – MyCalls screens on additional PC's
- Additional Sites – Collect call data from other SL systems

MyCalls - Installation

MyCalls can be installed in just a few steps.

- Enter the IP Address of the SL1000
- MyCalls detects the licenses and extracts the configuration from the SL PBX
- No Manual importing or filling of tables is required
- MyCalls can also setup the SMDR on the SL1000

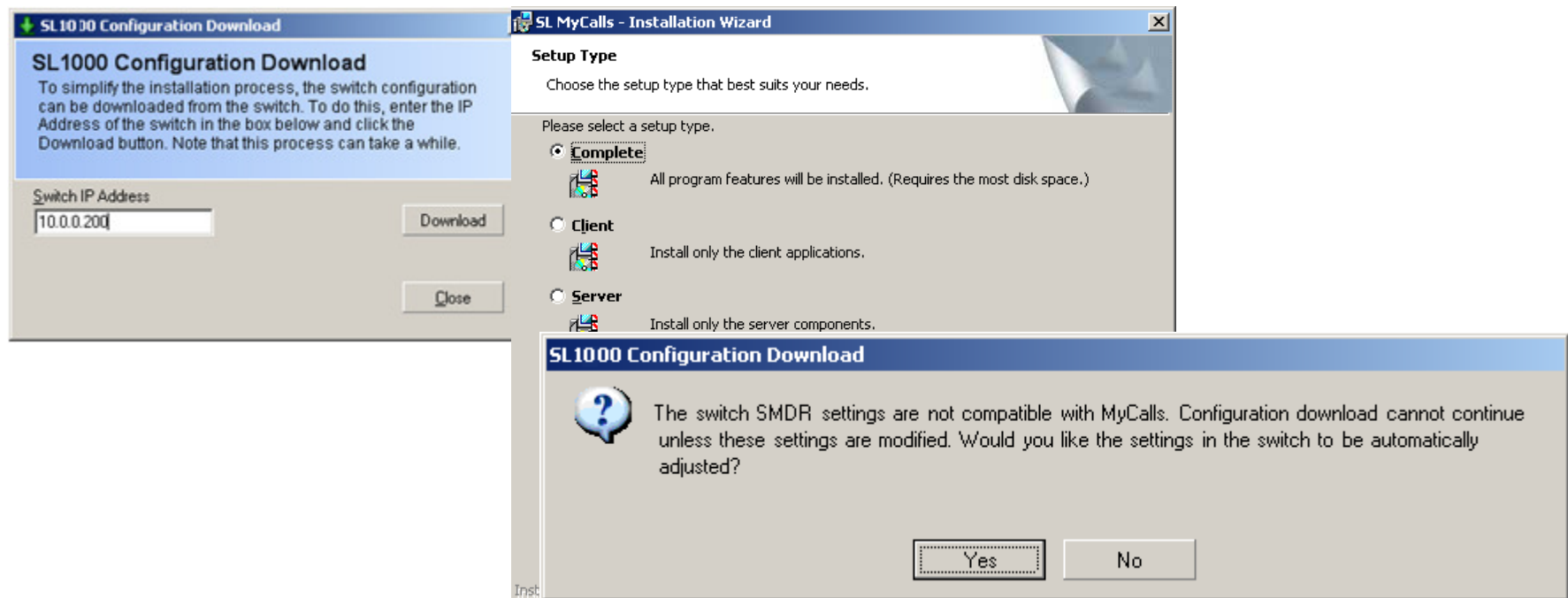

MyCalls Related Commands

- 10-20-01 Ext Device 5 port 4001
- 35-01-01 output Type 3
- 35-02-04 disable 0
- 35-02-05 disable 0
- 35-02-06 disable 0
- 35-02-07 disable 0
- 35-02-16 Both 2
- 80-05-01 European 2
- 15-01-03 Enable 1
- 14-01-06 Enable 1

Desktop Suite for the SL1000

Desktop Suite is an Intuitive Desktop Application that will help your staff to work even more efficiently. It can operate in 2 modes:

Deskset Mode

- Allows a user to perform call control on a desk phone i.e. Answer, Hangup Hold, transfer etc
- Can provide BLF using DSS keys that are programmed on the keyset
- Call Log / Speed dials
- Dial from and Screen Pop into Outlook

Softphone Mode

- Use your PC as a VOIP extension with all the features of the Deskset mode



Desktop Suite – Deskset Mode

- Call control provided by PC
- Voice path provided by Deskset (key telephone)
- Does Not require a VoIP card
- Requires a Deskset Control License (max. 128 clients)

The user can easily navigate to Call Control functions with the use of a Tool Bar.

- Available tool buttons
 - Dial, Redial
 - Hold, Transfer, Park
 - Page, call pickup, Barge In
 - DND, Forward
 - Conference
 - etc



Desktop Suite – Softphone Mode

Softphone and Desktop Modes have same look and feel

- Call control and voice provided by PC
- Requires VoIP card in SL1000
 - maximum 16 Softphones
- Requires a Softphone License

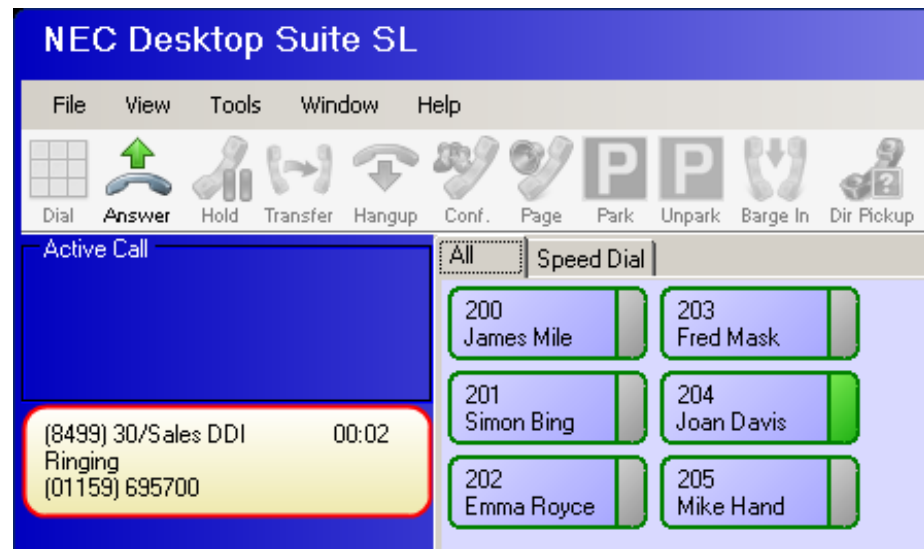

Desktop Suite - Installation

- The same software is installed for both Deskset mode and Softphone mode.
- A Clear Wizard guides you in the installation process
 - Enter IP address of the SL1000
 - Select Softphone or Deskset Mode
 - Choose the extension to control for Deskset Mode
 - Installation complete

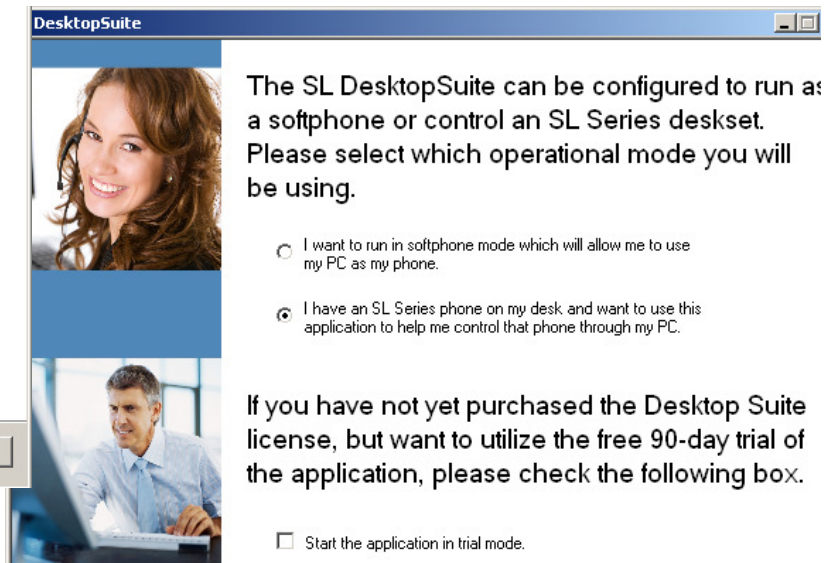
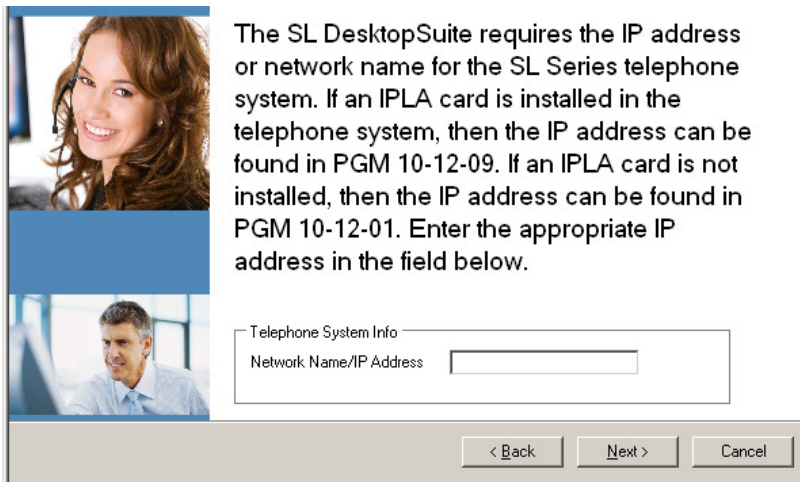

Desktop suite related commands

- 10-20-01 Device 9 CTI Port Number 8181
- 10-46-06 SIP port number 5080
- 10-47-01 license port number 6080
- 10-20-01 Device 11 O&M port 8010
- 90-02-01 UA user id : user1 password : 1111

System Comparison

Base Chassis



- Topaz : Base chassis supports 3 Trunks and 8 Hybrid ports
- ✓ SL1000 : Base chassis supports **4 Trunks** and 8 Hybrid ports

Single Chassis



- Topaz : Single chassis supports 9 analog / 16 BRI trunks + 24 hybrid extensions
- ✓ SL1000 : Single chassis supports **16 analog** / 12 BRI trunks + **32 hybrid** extensions

Expansion cards



- Topaz : Op-Box required on the Topaz for the BRI and VoIP cards
- ✓ SL1000 : **All cards** installed within the chassis

Auto Attendant



- Topaz : Requires additional option card
- ✓ SL1000 has **built in** 1-channel VRS or additional option card

System Comparison

Door phone



- Topaz needs additional PGDU card to connect a door phone
- ✓ SL1000 Door phones **connect to hybrid extension ports**

Rack Mounting



- Topaz : Can not be mounted in 19" rack when OP Box installed
- ✓ SL1000 : Can be mounted on a shelf in a **19" rack**

Ethernet



- Topaz : EXIFU card required for Ethernet port on the Topaz (PC Pro, SMDR...)
- ✓ SL1000 : Ethernet **built in** on the SL1000.

IP Terminal



- Topaz : No IP Terminal in the terminal range
- ✓ SL1000 : **IP Terminal** available

System Comparison



Softphone

- Topaz : No Softphone
- ✓ SL1000 : **Softphone** and Desktop phone control



Stock Inventory

- Topaz : 15 Parts to stock
- ✓ SL1000 : **Lower stock inventory** 12 Parts to stock



Hotel

- Topaz : Hotel feature set (using system phone)
- ✓ SL1000 : Hotel feature set (using system phone)



Remote Upgrade

- Topaz : No remote upgrade : Must visit site
- ✓ SL1000 : **Remote upgrade** (via ISDN)

System Comparison

Licenses



- Topaz : No Licenses
- ✓ SL1000 : Licenses give the opportunity for **more revenue**

Installation



- Topaz : PC Pro with Easy Edit
- ✓ SL1000 : PC Pro with Easy Edit and **new Drag and Drop GUI**

Training



- Topaz : 2 day class room training
- ✓ SL1000 : Class room or **Computer Based Training**

Voice Mail



- Topaz : Essentially a Personal Voice Mail System
- ✓ SL1000 : Personal and **Fully Featured** system Voice Mail

Terminal Line-up

Topaz has 12 terminal options

- 6 Key no display (Black or White)
- 12 Key no display (Black or White)
- 6 Key with display (Black or White)
- 12 Key with display (Black or White)
- 24 Key Add-on module (Black or White)
- DSS Console (Black or White)



SL1000 has 8 terminal options

- 12 key with display (Black or White)
- 24 key with display (Black or White)
- 24 key IP terminal (Black or White)
- DSS Console (Black or White)



Terminal Comparison

Topaz



SL1000



Terminal Type	Hybrid (4W) Multi-Line Terminal	Hybrid (4W) Multi-Line Terminal
Connected to	Hybrid Extension Port	Hybrid Extension Port
Color Line-Up	Black/White	Black/White
LCD	16 digits x 2 lines w/o Backlit	16 digits x 2 lines w/o Backlit
Programmable Keys	6/12 (BLF : Red/Green)	12/24 (BLF : Red/Green)
10 One Touch/Programmable keys	Yes	No
Soft Keys	No	No
Menu Cursor Key	No	Yes
Incoming LED	1 colour (Red)	1 colour (Red)
Handsfree	Half-duplex	Half-duplex
Backlit Dial Pad	No	No
Headset Port	No (use Handset Port)	No (use Handset Port)
Angle Adjustment	2-steps (Base)	2-steps (Base)
Key pad Language	English Only	Flexible (DESI label)
Wall Mounting Kit	Built-In	Built-In

Voice Mail Comparison : Example enhancements.....

Recording Capacity

- Topaz : 1 hour capacity (standard compact flash card)
- ✓ SL1000 : **15 hour capacity** (standard compact flash card)

Channels

- Topaz : 8 channels standard
- ✓ SL1000 : 2 channels standard (16 with MEMDB and License)

Transfer to Mail Box

- Topaz : No transfer to mail box
- ✓ SL1000 : **Transfer to mail box** (call extension press VM key, very easy operation)

Auto Attendant

- Topaz : Limited Auto Attendant (use VRS for Auto Attendant on the Topaz)
- ✓ SL1000 : **Flexible Auto Attendant** (16 Call Routing Mailboxes)

Message Notification

- Topaz : On your desk phone only
- ✓ SL1000 : **Flexible notification**, on desk phone, External number / Pager or E-Mail

Voice Mail box options

- Topaz : Limited Mail Box options available to callers (fixed code to escape from voice mail)
- ✓ SL1000 : **Flexible Mail Box Options** (Call Routing mailbox can be assigned , giving full flexibility)

SL1000 - Summary

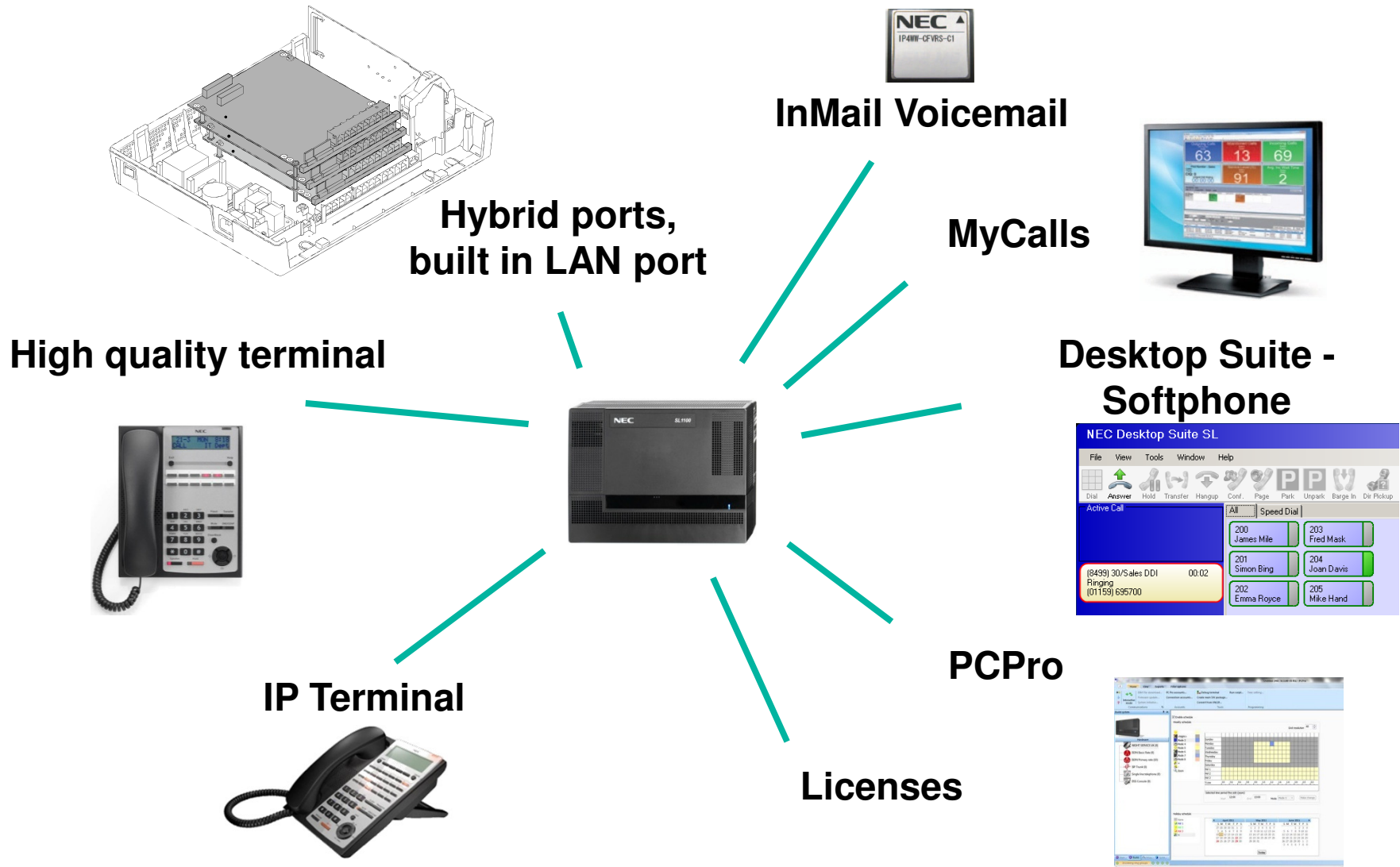

Empowered by Innovation

NEC